

Filter Unit

FA 016



Safety and operating instructions

Read safety and operating instructions before use.

Note: The indicated data only serve to describe the product. Information regarding the use of this product are only examples and suggestions. Catalog specifications are no guaranteed features. The information given does not release the user from his / her own assessments and inspection.

Our products are subject to a process of natural wear and aging.

© All rights are reserved by ARGO-HYTOS GMBH, even in the event of industrial property rights. Any right of disposal such as copying and distribution rights shall remain with us.

The picture on the title page shows a configuration example. The delivered product may thus differ from the illustration.

Contents

| | | |
|------------|---|-----------|
| | Contents | 2 |
| 1. | About this documentation | 4 |
| 1.1 | Applicability of this documentation..... | 4 |
| 1.2 | Required and supplementary documentation..... | 4 |
| 1.3 | Presentation of information..... | 4 |
| 1.3.1 | Safety instructions..... | 4 |
| 1.3.2 | Symbols..... | 5 |
| 1.3.3 | Terms..... | 5 |
| 1.3.4 | Abbreviations..... | 5 |
| 2. | Safety instructions | 6 |
| 2.1 | About this chapter..... | 6 |
| 2.2 | Intended use..... | 6 |
| 2.3 | Improper use..... | 6 |
| 2.4 | Reasonably foreseeable misuse..... | 6 |
| 2.5 | Qualification of personnel..... | 6 |
| 2.6 | General safety instructions..... | 7 |
| 2.7 | Product and technology related safety instructions..... | 7 |
| 3. | General instructions | 8 |
| 4. | Scope of delivery | 9 |
| 5. | About this product | 10 |
| 5.1 | Performance specification..... | 10 |
| 5.2 | Device description..... | 10 |
| 5.3 | Component overview..... | 10 |
| 5.4 | Identification of the product..... | 11 |
| 6. | Transport and storage | 12 |
| 6.1 | Transport..... | 12 |
| 6.2 | Storage..... | 12 |
| 7. | Assembly | 13 |
| 8. | Commissioning | 14 |
| 8.1 | Before commissioning..... | 14 |
| 8.2 | After switching on..... | 14 |
| 8.3 | In case of power failure..... | 14 |
| 9. | Operation | 15 |
| 9.1 | Filtering hydraulic fluids when refilling..... | 15 |
| 9.2 | Filtering liquids in the bypass flow..... | 16 |
| 10. | Maintenance / repair | 17 |
| 10.1 | Maintenance..... | 18 |
| 10.2 | Maintenance overview..... | 18 |
| 10.2.1 | Replacing the suction strainer..... | 18 |
| 10.3. | Replacing the filter element..... | 19 |
| 10.3.1 | Removing the filter element..... | 19 |
| 10.3.2 | Removing the filter element from the cover..... | 19 |
| 10.3.3 | Attaching the filter element..... | 19 |
| 10.3.4 | Installing the filter element..... | 19 |
| 10.4 | Replacing the pump..... | 20 |

| | | |
|------------|-------------------------------------|-----------|
| 10.4.1 | Removing the pump..... | 21 |
| 10.4.2 | Installing the pump..... | 21 |
| 10.5 | Replacing the motor..... | 21 |
| 10.5.1 | Removing the motor..... | 22 |
| 10.5.2 | Installing the motor..... | 22 |
| 11. | Decommissioning..... | 23 |
| 12. | Disassembly..... | 24 |
| 13. | Disposal..... | 25 |
| 14. | Extension..... | 26 |
| 14.1 | Optional accessories..... | 26 |
| 14.1.1 | Mobile transport aid / trolley..... | 26 |
| 14.1.2 | Hose extensions..... | 26 |
| 15. | Troubleshooting..... | 27 |
| 15.1 | How to proceed..... | 27 |
| 15.2 | Fault table..... | 28 |
| 16. | Technical data..... | 29 |
| 16.1 | Device dimensions..... | 29 |
| 16.2 | Technical data..... | 30 |
| 16.3 | Operating conditions..... | 31 |
| 16.4 | Hydraulic circuit diagrams..... | 31 |
| 17. | Appendix..... | 32 |
| 17.1. | Declaration of Conformity..... | 32 |
| 17.2 | Spare parts list..... | 33 |

1. About this documentation

1.1 Applicability of this documentation

This documentation is applicable for the following product:

- › Filter Unit FA 016

This documentation is written for technicians, operators, service engineers and system operators.

This document contains important information for safe and appropriate assembly, transport, activation, operation, usage, servicing, dismantling and simple troubleshooting.

- › Read this document completely and in particular Chapter 2, "Safety Instructions", before you work with the product.

1.2 Required and supplementary documentation

Do not commission the product until you have received the documentation marked with the book icon and before you have understood and complied with the information therein.

| | Title | Number of document | 1.2.1 Document type |
|---|------------|--------------------|---------------------|
|  | Data sheet | 80.65 | PDF |

Table 1: Required and supplementary documentation

1.3 Presentation of information

So that this document can help you to work quickly and safely with your product, we use standardized safety instructions, symbols, terms and abbreviations. For better understanding, these are explained in the following sections.

1.3.1 Safety instructions

In this documentation, safety instructions are faced with a sequence of actions which would result in the danger of personal injury or damage to equipment. The measures described to avoid these hazards must be observed.

|  DANGER | |
|---|---|
|  | Type and source of danger <ul style="list-style-type: none">› Consequences of the danger› Escaping or averting the danger› Rescue (optional) |

- › Warning signal: draws attention to the danger
- › Signal word: indicates the severity of the danger
- › Type and source of danger: specifies the type and source of danger
- › Consequences: describes the consequences in the event of non-compliance
- › Action: indicates how the danger can be avoided



| Warning sign, signal word | Meaning |
|--|--|
|  DANGER | Indicates a dangerous situation which results in death or serious injury if not avoided. |
|  WARNING | Indicates a dangerous situation which may result in death or serious bodily injury if not avoided. |
|  CAUTION | Indicates a dangerous situation which may result in light to moderate injury if not avoided. |
| NOTE | Indicates property damage: The product or surrounding could be damaged. |

Table 2: Meaning of the warning signs

1.3.2 Symbols

The following symbols indicate notes which are not safety-relevant but increase the intelligibility of the documentation.









| Symbol | Meaning |
|---|---|
|  | If this information is not observed, the product cannot optimally be used or operated |
|  | Singular, independent action step / instruction |
| 1. 2. 3. | Numbered instruction The numbers indicate that the action steps follow one another |
|  | This symbol indicates danger to equipment, material and environment |
|  | This symbol indicates the risk of personal injury (minor injury). |
|  | This symbol indicates the risk of personal injury (death, serious bodily injury). |
|  | This symbol specifies that protective gloves should be worn. |
|  | This symbol specifies that safety shoes should be worn. |
|  | This symbol specifies that protective goggles should be worn. |
|  | This symbol specifies that the unit should be disconnected from the power supply. |

Table 3: Meaning of symbols

1.3.3 Terms

In this documentation the following terms are used:

| Term | Meaning |
|------|---------|
| | |

Table 4: Terms

1.3.4 Abbreviations

In this documentation the following abbreviations are used:

| Term | Meaning |
|------|-------------|
| FA | Filter Unit |

Table 5: Abbreviations

2.1 About this chapter

This product was manufactured according to the generally recognized standards of engineering. Nevertheless, there is a danger of injury or damage if you do not observe this chapter and the safety instructions in this documentation.

- ▶ Read this document thoroughly and completely before working with the product.
- ▶ Retain this document and ensure that it is available for all users at all times.
- ▶ Always include the necessary documentation when passing the equipment along to a third party.

2.2 Intended use

This product is a hydraulic component.

You may use the product for the following:

- › for filtration of lubricating and hydraulic oils during filling of machines and systems, taking the technical data into account;
- › for filtration of hydraulic fluids in the bypass flow at machines and systems, taking the technical data into account.

This product is intended for professional use only, and not for private use.

"Intended use" also includes that you have completely read and understood this documentation, in particular Chapter 2 "Safety Instructions".

2.3 Improper use

Any other use than the intended use described, is improper and inadmissible.

If unsuitable products are installed or used in safety-related applications, unintended operating states may occur in the application, which may cause personal injury and / or property damage.

Therefore only use this product in safety-related applications if this use is explicitly specified and permitted in the product documentation, e.g. in explosion protection areas or in safety-related parts of a control system (functional safety).

ARGO-HYTOS GMBH assumes no liability for damages resulting from improper use. The risks associated with improper use are solely with the user.

2.4 Reasonably foreseeable misuse

The delivery of the following media is forbidden:

- › flammable liquids such as petrol or thinner (explosion hazard)
- › foodstuffs
- › oil sludge and residues

The device is not suitable for sucking sludge and sediment.

The operator alone is liable for damages resulting from improper use.

2.5 Qualification of personnel

The operations described in this document require fundamental knowledge of mechanics and hydraulics as well as knowledge of the appropriate technical terms. In order to ensure safe use, these operations may therefore only be carried out by a correspondingly skilled worker or an instructed person under the guidance of a skilled worker.

A skilled worker is someone who can - based on his / her technical education, knowledge and experience as well as knowledge of the respective regulations of the jobs assigned to him / her - recognize possible dangers and ensure appropriate safety measures.

A skilled worker must observe the relevant technical regulations.

The device may be operated by the following individuals:

- › Persons aged 14 years or older who have read and understood these operating instructions.
- › Persons aged 14 years or older who have been instructed by trained staff.
- › Qualified / specialised staff with adequate training.

The device may be repaired or maintained by the following individuals:

- › Qualified / specialised staff with adequate training.





Work on electrical components:

- › Only electrical specialists with adequate training.





2.6 General safety instructions

- › Observe the valid regulations for accident prevention and environmental protection.
- › Observe the safety regulations and requirements of the country in which the product is used / applied.
- › Only use ARGO-HYTOS products that are in technically perfect condition.
- › Observe all instructions on the product.
- › People who assemble, operate, disassemble or maintain ARGO-HYTOS products may not do so under the influence of alcohol, other drugs or medications that affect the responsiveness.
- › Only use manufacturer-approved accessories and spare parts, in order to prevent personal danger due to unsuitable spare parts.
- › Observe the technical data and ambient specifications specified in the product documentation.
- › If unsuitable products are used or installed in safety-relevant applications, unintended operating states may occur in the application, which can cause personal injury and / or material damage. Therefore only use the product in safety-relevant applications if this use is explicitly specified and permitted in the product documentation.
- › You may only put the product into operation, when it has been established that the final product (e.g. a machine or system), into which the ARGO-HYTOS products have been installed, complies with the country-specific regulations, safety regulations and standards of the application.

2.7 Product and technology related safety instructions

|  CAUTION | |
|--|---|
|  | <p>Hydraulic oil spills Environmental hazard / risk of slipping.</p> <ul style="list-style-type: none"> ▶ In case of spills, cover the oil-covered surface immediately with an oil-binding medium. ▶ Then immediately dispose of the oil-binding medium according to the national environmental regulations. |
|  | <p>Ignition hazard Risk of electrostatic charge by poorly conducting hydraulic fluid.</p> <ul style="list-style-type: none"> ▶ If the electrical conductivity of the hydraulic fluid is not known, please contact the manufacturer of the hydraulic fluid. |
|  | <p>Risk of burns Contact temperatures according to DIN EN563 (3) and DIN EN13202 (4) may be exceeded during operation.</p> <ul style="list-style-type: none"> ▶ Allow the filter unit to cool down before touching it. |

For prevention of material damage and product damage

|  CAUTION | |
|--|---|
|  | <p>Danger due to improper handling Property damage</p> <ul style="list-style-type: none"> ▶ The filter unit may only be used in accordance with Section 2.2, "Intended use". <p>Leakage or spillage of hydraulic fluid Environmental pollution and ground water contamination.</p> <ul style="list-style-type: none"> ▶ Use an oil binding agents in order to bind leaked hydraulic oil. |
|  | <p>Risk of burns Contact temperatures according to DIN EN563 (3) and DIN EN13202 (4) may be exceed during operation.</p> <ul style="list-style-type: none"> ▶ Allow the filter unit to cool down before touching it. <p>Contamination due to fluids and foreign bodies Premature wear - malfunction - risk of damage - property damage.</p> <ul style="list-style-type: none"> ▶ Ensure cleanliness during installation in order to prevent foreign bodies, such as welding beads or metal chips, from entering the hydraulic lines, leading to premature wear or malfunction. ▶ Make sure that connections, hydraulic lines and attachment parts (e.g. gauges) are free of dirt and chips. ▶ Prior to commissioning, check that all hydraulic and mechanical connections are connected and tight, and that all gaskets and seals of the plug connectors are correctly assembled and undamaged. ▶ For removal of lubricants and other contaminants, use residue-free industrial wipes. ▶ Make sure that all connections, hydraulic lines and attachment parts are clean. ▶ Ensure that no contaminants enter when closing the connections. ▶ Make sure that no detergents enter the hydraulic system. ▶ Do not use cotton waste or faying cleaning rags for cleaning. ▶ Do not use hemp as sealing agent. |
|  | <p>Improper cleaning Premature wear, malfunctions! Risk of damage! Property damage.</p> <ul style="list-style-type: none"> ▶ Close all openings with appropriate protective fittings to prevent penetration of detergents. ▶ Do not use aggressive cleaning agents for cleaning. Clean the product with a suitable cleaning fluid. ▶ Do not use a high pressure cleaner. ▶ Do not use compressed air to clean function interfaces such as seal areas. |

4. Scope of delivery

The package includes:

- › 1 Filter Unit FA 016
- › 1 Operating manual

5. About this product

5.1 Performance specification

The filter unit FA 016 is a mobile filter unit for filtration of hydraulic fluids and lubricants with a viscosity of 15 mm²/s - 200 mm²/s (in continuous operation) in the bypass flow (400 mm²/s max. in short-term operation).

A separate installation in the bypass or cooling circuit for fine filtration and discharge of the full flow filter is just as possible as the filtration of fresh oil and the cleaning (flushing) of polluted systems for wear protection of components and systems.

The volume flow is 16 l/min (50 Hz).

The operating temperature is in the range of 0° C to 65° C.

5.2 Device description

The filter unit FA 016 consists of a support frame in which a filter pump unit is integrated. This consists of an electrically operated filter pump with exchangeable filter element and a gauge as maintenance indicator.

The on/off switch is located in the control box of the pump motor. The suction hose is connected to the suction port of the pump and the pressure hose at the output of the main filter.

5.3 Component overview

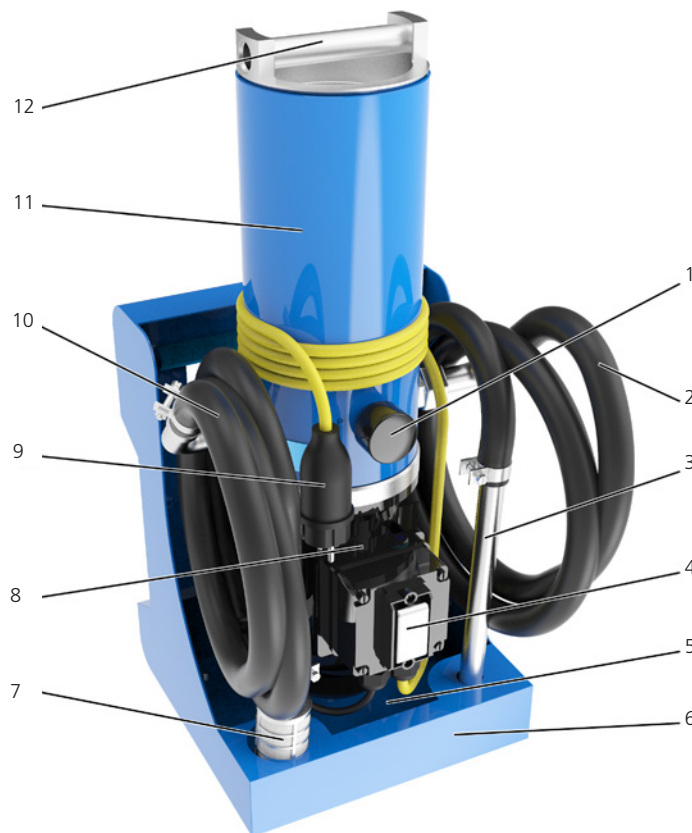

Fig.1: Component overview

- | | | | |
|---|--------------------|----|------------------------------------|
| 1 | Clogging indicator | 7 | Suction bell |
| 2 | Pressure hose | 8 | Electric motor |
| 3 | Discharge pipe | 9 | Power supply cable |
| 4 | On/off switch | 10 | Suction hose |
| 5 | Oil sump | 11 | Filter housing with filter element |
| 6 | Carrying frame | 12 | Filter cover |

5.4 Identification of the product

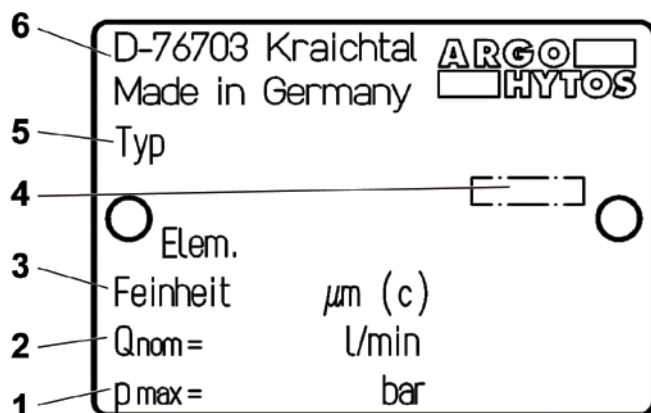

Fig. 2: Nameplate

- | | | | |
|---|---------------------|---|---------------------|
| 1 | Max. pressure | 4 | Year of manufacture |
| 2 | Nominal volume flow | 5 | Type designation |
| 3 | Filter fineness | 6 | Address |

NOTE

Nameplates are documents which mustn't be changed or removed.

- ▶ Damaged or lost nameplates have to be replaced true to the original.

6. Transport and storage

6.1 Transport

CAUTION



Falling unit through incorrect transport

Injury and property damage

- ▶ The unit must be carried manually by two persons due to its own weight of 22 kg.
- ▶ Wear safety shoes when transporting the filter unit.



Transport

The compact design allows for easy transport of the filter unit FA 016 - even in inaccessible areas of hydraulic systems. Hoses and electrical cables can be attached to the device. The device can be transported or operated both standing and lying. Observe the notes in Chapter 2 "General safety instructions".

- ▶ When using mobile transport aids, ensure a secure position of the unit (danger of tipping).
- ▶ During transport, fix the suction and pressure hose in the provided supports in order to avoid a possible leakage of residual oil.

6.2 Storage

The filter unit FA 016 should be stored in an enclosed area to protect it from humidity and condensation.

CAUTION



Risks related to chemical reactions

Risk of injury

- ▶ Chemical substances in the immediate vicinity of the filter unit may react and lead to destruction of the device and to injuries of persons who are in the immediate vicinity of the device
- ▶ Storage in the immediate vicinity of chemically active substances such as acids, alkalis, salts, organic solvents and rechargeable batteries is prohibited.

The ambient temperature during storage of the filter unit FA 016 should be between + 5 °C and + 30 °C at a humidity of 80 %. Before storage over a period of more than 6 months, the unit should be filled with oil in order to preserve it against corrosion.



WARNING



Faulty power supply

Risk of death and injury

- ▶ Always consider the country-specific regulations.

Let - prior to commissioning - an electrician check whether:

- › the mains voltage matches with the voltage specified on the typeplate of the motor,
- › the power source has appropriately been secured,
- › the cross-section is of sufficient size,
- › cable and connection to the power source are in perfect condition.

With 3-phase AC motors check after connecting that:

- › when switching on, the direction of rotation matches with the direction arrow on the motor, if not, have it changed by an electrician.

Specifically, proceed with the following steps:

- › Connect the 230 V voltage plug to the local power supply.

8.1 Before commissioning

- ▶ Be sure to read and understand the operating manual before putting the device into operation.
- ▶ The information for intended use, the operating conditions and the technical specifications must be adhered to.
- ▶ The unit must be positioned so that there is no danger of tipping and vibrations are largely intercepted.
- ▶ Cables and hoses must be outside of the movement range of the operating personnel (tripping hazard).
- ▶ If no hydraulic oil is sucked in during commissioning, switch off the unit, open the cover at the filter housing and fill in approx. 0.3 l hydraulic oil.
- ▶ The oil to be filtered must be compatible with the previously filtered hydraulic oil. If this is not the case, the filter unit must be cleaned and the filter element is to be replaced (see filter element change).
- ▶ When using the hoses during unmanned operation, ensure that they might not fall out of the container.
- ▶ The suction and discharge pipe must be immersed far enough below the liquid level, so that oil is sucked in.
- ▶ The hydraulic fluid must be free of water (no oil turbidity).
- ▶ Properly close the cover of the filter housing.
- ▶ Manually turn the cover until it stops; a gap between cover and housing may remain visible (see Figure 3).

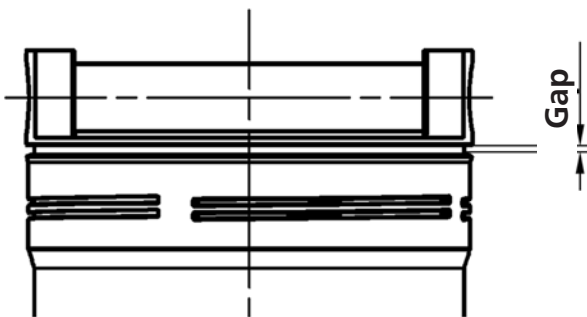

Fig. 3: Gap at the filter cover



8.2 After switching on

- ▶ With 3-phase AC motors check after connecting if the direction of rotation matches with the direction arrow on the motor. If not, have it changed by an electrician.
- ▶ Check the filter unit for leaks.

8.3 In case of power failure

In order to prevent unintentional starting of the unit, always switch off and unplug the unit.

 **CAUTION**

| | |
|---|--|
|  | <p>Exposure to spilled oil Injury / risk of slipping</p> <ul style="list-style-type: none"> ▶ If oil leaks, the oil-covered area must be shut off immediately and covered with an oil binding medium (risk of slipping). |
|  | <p>Static charge Sparking</p> <ul style="list-style-type: none"> ▶ There is a risk of static charge when using poorly conducting hydraulic or lubricating oils. In this case, please consult the manufacturer. |

NOTE

Damage to the filter unit by missing or defective suction strainer.

Property damage.

- ▶ The strainer must be regularly checked according to the maintenance intervals and replaced if necessary.
- ▶ The filter unit is provided with a protective strainer at the suction side, which has to be serviced regularly. A missing protective strainer may lead to destruction of the pump. (Order No. see spare parts list)
- ▶ If the protective strainer is removed, the manufacturer will resume no liability.

9.1 Filtering hydraulic fluids when refilling

1. Connect the filter unit to a power source.
2. Place the suction strainer into the oil drum.
3. Place the discharge pipe into a container (e.g. hydraulic tank).

NOTE

Faulty insertion of the discharge pipe

- ▶ Make sure that the discharge pipe is below the liquid surface.
4. Turn the filter unit on at the on/off switch (circuit breaker).
 5. Check the oil flow on possibly insufficient immersion depth of the suction pipe in the oil tank.

NOTE

Faulty insertion of the discharge pipe

- ▶ At the beginning of the filtration, filling of the filter unit may take a few seconds.
6. Using the clogging indicator, check the element for clogging at operating temperature of the medium used.
 7. Check the filling level at the machine or system and turn off the filter unit at the circuit breaker, once the desired filling quantity has been reached.
 8. Re-attach the suction strainer and the discharge pipe at the appropriate brackets at the filter unit.

9.2 Filtering liquids in the bypass flow

1. Connect the filter unit to a power source.
2. Place the suction strainer into the container of the machine or system (e.g. hydraulic tank).
3. Place the discharge pipe in a container of the machine or system (e.g. hydraulic tank).
4. Turn the filter unit on at the on/off switch (circuit breaker).
5. Check the oil flow on possibly insufficient immersion depth of the suction pipe in the oil tank.

NOTE

Faulty insertion of the discharge pipe

- ▶ At the beginning of the filtration, filling of the filter unit may take a few seconds.



6. Using the clogging indicator, check the element for clogging at operating temperature of the medium used.
7. At the end of filtration, pull the suction strainer out of the container of the machine or unit (e.g. hydraulic tank) and draw in air for max. 30 seconds.
Thus, residual oil from the filter housing and the lines above oil level will be returned via the discharge pipe into the tank of the machine or unit.
8. Turn off the filter unit by using the circuit breaker.
9. Re-attach the suction strainer and the discharge pipe to the appropriate brackets at the filter unit.

NOTE





Reaching the maximum cleaning performance

- ▶ In order to prevent a short circuit of the oil flow, the distance between the suction and pressure connection should be kept as large as possible.

 **DANGER**

| | | |
|---|---|---|
|  |  | <p>Danger to life Risk of electric shock</p> <ul style="list-style-type: none"> ▶ During repair work, turn off the unit and pull the mains plug. |
|---|---|---|

 **CAUTION**

| | |
|---|--|
|  | <p>Risks related to chemical reactions Risk of injury</p> <ul style="list-style-type: none"> ▶ Chemical substances in the immediate vicinity of the filter unit may react and lead to destruction of the device and to injuries of persons who are in the immediate vicinity of the device ▶ Storage in the immediate vicinity of chemically active substances such as acids, alkalis, salts, organic solvents and rechargeable batteries is prohibited. |
|  | <p>Hydraulic oil spills Environmental hazard / risk of slipping</p> <ul style="list-style-type: none"> ▶ Before maintenance and repair work, completely drain the unit. ▶ In case of spills, cover the oil-covered surface immediately with an oil-binding medium. ▶ Then immediately dispose of the oil-binding medium according to the national environmental regulations. |
|  | <p>Ignition hazard Risk of electrostatic charge by poorly conducting hydraulic fluid.</p> <ul style="list-style-type: none"> ▶ If the electrical conductivity of the hydraulic fluid is not known, please contact the manufacturer of the hydraulic fluid. |
|  | <p>Risk of burns Contact temperatures according to DIN EN563 (3) and DIN EN13202 (4) may be exceeded during operation.</p> <ul style="list-style-type: none"> ▶ Allow the filter unit to cool down before touching it. |

NOTE

| |
|--|
| <p>Impaired function by dirt ingress into the pump. The function of the filter unit is no longer guaranteed.</p> <ul style="list-style-type: none"> ▶ During repair work, all parts coming in contact with the hydraulic medium, must be kept free of dirt and chips. |
|--|

10.1 Maintenance

10.2 Maintenance overview

Except from the filter element and the suction strainer, the filter unit is maintenance-free.

| Maintenance work | Order No. | Maintenance interval |
|--|---|--|
| Checking / changing the filter element | V7.1220-113 (3 µm) V7.1220-13 (5 µm) V7.1220-06 (10 µm) | Once the clogging indicator changes to the red range at a permissible viscosity |
| Checking / changing the suction strainer | FA 016.0110 | ¼-annually or with corresponding problems (lower volume flow with clean filter element, too loud noise level). |

Table 6: Maintenance overview

10.2.1 Replacing the suction strainer

NOTE

Damage to the filter unit by missing or defective suction strainer.

Damage

- ▶ The suction strainer must be regularly checked and replaced if necessary, according to the maintenance intervals.

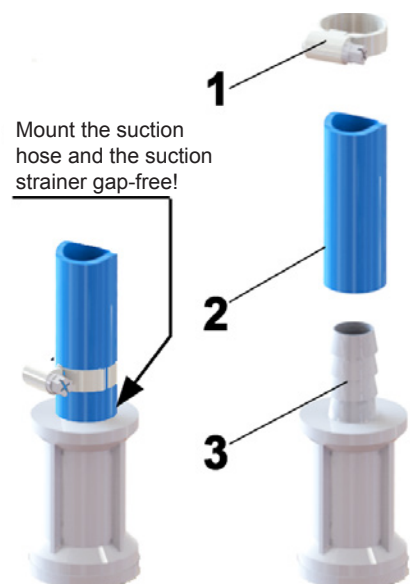

Fig. 4: Changing the suction strainer

1. Loosen the hose clamp (1).
2. Disconnect the suction strainer (3) from the suction hose (2).
3. Clean the suction strainer (3) using benzine or diesel fuel.

NOTE

- ▶ In case of damage, replace the suction strainer (3) (Order No. FA 008.0110).

4. Push the suction hose (2) - as shown above - onto the suction strainer (3)
5. Attach the hose clamp (1).

10.3. Replacing the filter element

1. Pump the filter element dry - (see Chapter 9.2 "Filtering liquids in the bypass flow" Point 7)
2. Turn the filter unit on at the on/off switch (circuit breaker) and pull the mains plug.

| ! CAUTION | |
|---|---|
|  | <p>Risk of burns</p> <p>Contact temperatures according to DIN EN563 (3) and DIN EN13202 (4) may be exceeded during operation.</p> <ul style="list-style-type: none"> ▶ No fluid may pass through the filter while the filter element is being replaced. ▶ Allow the filter unit to cool down before touching it. |

10.3.1 Removing the filter element



Fig. 5: Removing the filter element

1. Turn the housing cover (1) counterclockwise.
2. Carefully remove the cover (1) with the filter element (2) from the filter tube. (The filter element is attached to the cover. Let the draining oil drip off into the housing.)

10.3.2 Removing the filter element from the cover



Fig. 6: Removing the filter element from the cover

1. Push the filter element at the cover in arrow direction 1 and remove it in arrow direction 2.
2. Dispose of the filter element according to the national environmental legislation (Waste code: Oil filter 16 01 07).

10.3.3 Attaching the filter element



Fig. 7: Attaching the filter element

1. Check the filter element type number. Does the load inscription on the filter element match with the indications on the typeplate or in the operating manual?
2. Attach the filter element in arrow direction 2 and lock it in arrow direction 1.

10.3.4 Installing the filter element

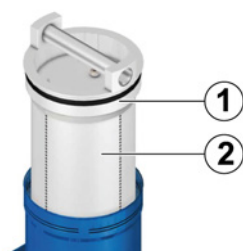







Fig. 8: Installing the filter element

1. Always replace the O-ring in the cover, when changing the filter element (part of the scope of delivery of the filter element) (O-ring Order No. N007.1175, included in spare filter elements).
2. Carefully insert the cover (1) with the filter element (2) into the filter tube.
3. Screw in the cover manually until it stops. A gap between cover and filter pipe may remain visible (see Chapter 8.1 "Before commissioning" / Fig. 3)

10.4 Replacing the pump

|  DANGER | |
|---|---|
|  | <p>Danger to life Risk of electric shock</p> <p>▶ Before uninstalling, pull the mains plug. Uninstalling may only be carried out by qualified electricians.</p> |
|  | <p>Risk of injury Risk of injury by incorrect handling</p> <p>▶ Uninstalling may only be carried out by instructed persons.</p> |
|  CAUTION | |
|   | <p>Risk of burns Contact temperatures according to DIN EN563 (3) and DIN EN13202 (4) may be exceeded during operation.</p> <p>▶ Allow the filter unit to cool down before touching it.</p> |

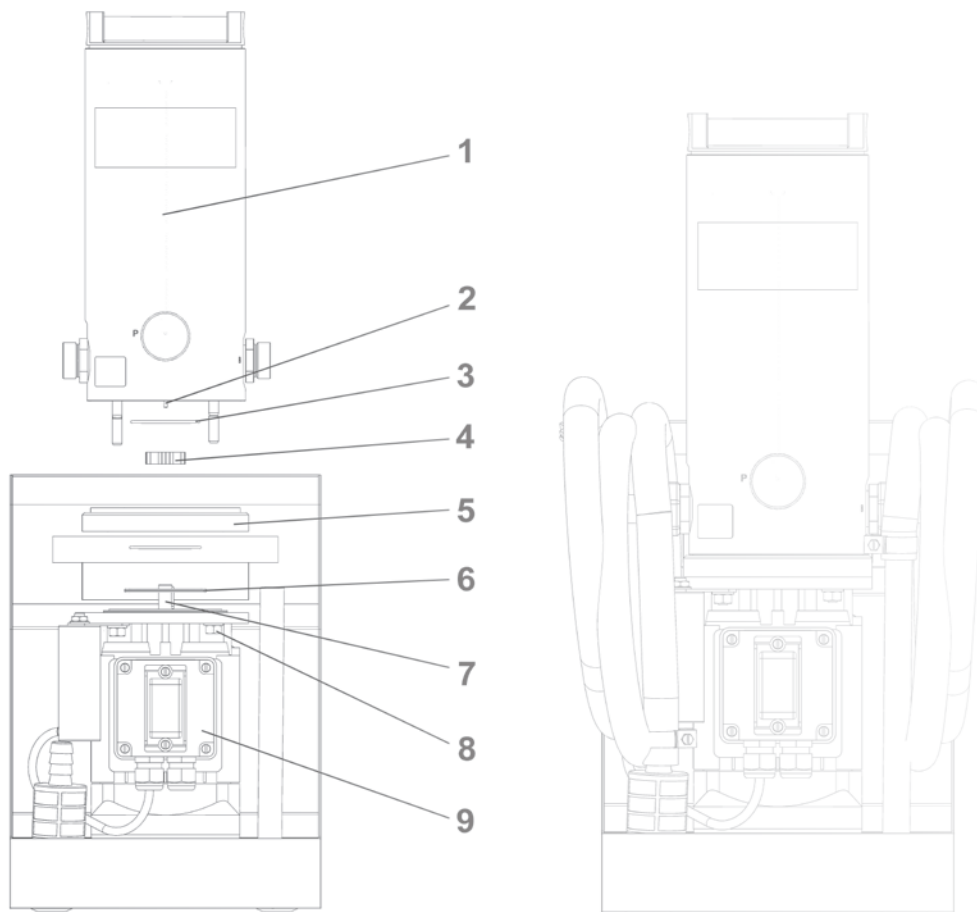

Fig. 9: Replacing the motor and the pump

10.4.1 Removing the pump

1. Loosen the hexagon nuts (Pos. 8).
2. Lift the module "filter pipe and housing" (Pos. 1) upwards.
3. Loosen the pump plate (Pos. 5) together with the wheel set (consisting of outer rotor and inner rotor, Pos. 4) from the motor by gently pulling upwards.
4. Dispose of the pump plate, the wheel set and the O-rings according to the national environmental legislation.

NOTE

- ▶ When replacing the pump, the O-rings (Pos. 3 and Pos. 6) must always be replaced by new O-rings. Please take the Order No. from the spare parts list.

10.4.2 Installing the pump

1. Assemble the outer and the inner rotor (Pos. 4) and place them into the designated cut-out in the pump plate. The installation position is optional.
2. Lubricate the O-rings (Pos. 3 and Pos. 6) and insert them into the provided O-ring grooves in the pump plate.
3. Attach the preassembled pump plate (Pos. 5 with Pos. 4) onto the motor.
Insert the key of the motor shaft (Pos. 7) in one of the four key grooves of the inner rotor.

NOTE

- ▶ When pressing the pump plate onto the motor, please check that the O-ring (Pos. 6) does not slide out of the O-ring groove and will be damaged between motor and pump plate.
- ▶ The hole for the pin (rotation lock Pos. 2) must be opposite of the terminal box.

4. Wet or fill the wheel sets of the pump with oil.
5. Re-attach the assembly filter tube with the housing (Pos. 1) to the pump plate and the motor.

NOTE

- ▶ When mounting the filter pipe, ensure that the O-ring (Pos. 3) does not slide out of the O-ring groove and will be damaged between the pump plate (Pos. 4) and the housing (Pos. 1).



6. Screw the assembly with the nuts (Pos. 8) together (tightening torque 15⁺² Nm).

The device can be put into operation.

If not oil is sucked during commissioning, open the cover at the filter housing and fill with about 300 ml oil.

10.5 Replacing the motor

DANGER

| | |
|---|---|
|  | <p>Danger to life Risk of electric shock</p> <ul style="list-style-type: none"> ▶ Before uninstalling, pull the mains plug. Uninstalling may only be carried out by qualified electricians. |
|  | <p>Risk of injury Risk of injury by incorrect handling</p> <ul style="list-style-type: none"> ▶ Uninstalling may only be carried out by instructed persons. |

CAUTION

| | |
|---|--|
|  | <p>Risk of burns Contact temperatures according to DIN EN563 (3) and DIN EN13202 (4) may be exceeded during operation.</p> <ul style="list-style-type: none"> ▶ Allow the filter unit to cool down before touching it. |
|---|--|

10.5.1 Removing the motor

1. Loosen the hexagon nuts (Pos. 8).
2. Lift the module "filter pipe and housing" (Pos. 1) upwards.
3. Loosen the pump plate (Pos. 4) together with the wheel set (consisting of outer rotor and inner rotor, Pos. 5) from the motor by gently pulling upwards.
4. Loosen the motor from the bracket.
5. Dispose of the motor according to the national environmental legislation.

NOTE

- ▶ When replacing the pump, the O-rings (Pos. 3 and Pos. 6) must always be replaced by new O-rings. Please take the Order No. from the spare parts list.

10.5.2 Installing the motor

1. Mount the motor on the bracket.
2. Lubricate the O-rings (Pos. 3 and Pos. 6) and insert them into the provided O-ring grooves in the pump plate.
3. Attach the preassembled pump plate (Pos. 5 with Pos. 4) onto the motor.
Insert the key of the motor shaft (Pos. 8) in one of the four key grooves of the inner rotor.

NOTE

- ▶ When pressing the pump plate onto the motor, please check that the O-ring (Pos. 6) does not slide out of the O-ring groove and will be damaged between motor and pump plate.
- ▶ The hole for the pin (rotation lock Pos. 3) must be opposite of the terminal box.

4. Wet or fill the wheel sets of the pump with oil.
5. Attach the assembly filter tube with the housing (Pos. 1) to the pump plate and the motor.

NOTE

- ▶ When mounting the filter pipe, ensure that the O-ring (Pos. 3) does not slide out of the O-ring groove and will be damaged between the pump plate (Pos. 5) and the housing (Pos. 1).

6. Screw the assembly with the nuts (Pos. 8) together (tightening torque 15⁺² Nm).

The device can be put into operation.

If not oil is sucked during commissioning, open the cover at the filter housing and fill with about 300 ml oil.



DANGER



Danger to life

Risk of electric shock

- ▶ Before uninstalling, pull the mains plug. Uninstalling may only be carried out by qualified electricians.



Risk of injury

Risk of injury by incorrect handling

- ▶ Uninstalling may only be carried out by instructed persons.

The final decommissioning and disposal requires complete uninstallation of the total energy supply, the mechanical components and the disposal of the hydraulic media remaining in the device.

With disassembly and disposal, all national safety and environmental regulations must be observed.

The filter unit is a device that does not need to be dismantled.

13. Disposal

Careless disposal of the filter unit FA 016 and the hydraulic fluid can lead to environmental pollution. Therefore, dispose of the filter unit and the hydraulic fluid in accordance with the national regulations of your country. Dispose of hydraulic fluid residues according to the applicable safety data sheets for these hydraulic fluids.

14. Extension

14.1 Optional accessories

14.1.1. Mobile transport aid / trolley

Order no. FA 016-1760

For easy transport of filter unit FA 016 it is possible to hook a trolley onto the standing device. This allows effortless transport even over long distances.



Fig. 10: Optional accessory "Trolley"

14.1.2 Hose extensions

On request, ARGO-HYTOS also provides you with hose extensions according to your stipulations.

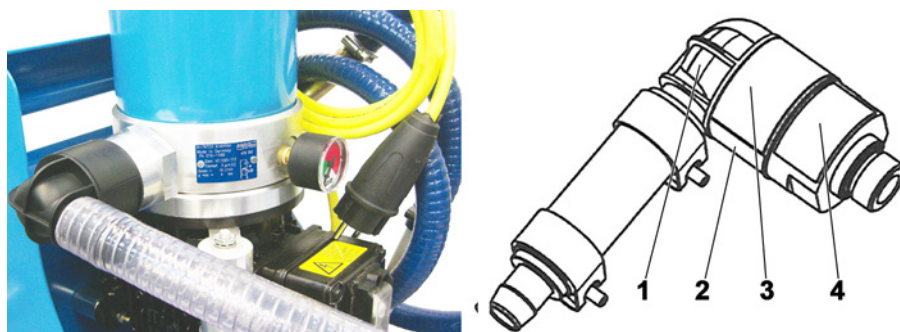

Fig. 10: Option "Suction strainer set"

The suction strainer set FA 016.1775 guarantees pump protection, when the existing suction strainer at the suction pipe cannot be used. This is the case, when the filter unit is to be mounted to the hydraulic unit by quick fitting coupling or ball valve, or the opening of the tank is not sufficiently dimensioned.

The suction strainer set FA 016.1775 consists of the suction strainer element 280 µm (2), a clip (3), a connection part with O-ring (4) and a connection piece (1).

The suction strainer set FA 016.1775 is designed in a way, so that the DN 25 hose connection can be rotated by 360° and thus be adapted to the position of the pipe inlet.

15.1 How to proceed

- › Get an overview on the function of the product in connection with the overall system.
- › Try to find out whether the product had provided the required function in the overall system before the error occurred.
- › Try to detect changes in the overall system, into which the product has been installed:
 - Have the operating conditions or the operating range of the product changed?
 - Have modifications (e.g. conversions) or repairs been carried out at the overall system (device/unit, electrics, control) or at the product? If so, which modifications?
 - Has the product or the device been operated correctly?
 - How does the fault tend to show?
- › Get a clear impression about the cause of trouble. Possibly consult the direct operator or machine operator.

15.2 Fault table

| Problem / fault | Possible cause | Elimination |
|--|---|---|
| › Electric motor does not turn on during commissioning | Electrical cable or mains plug defective | Have the cable replaced by a skilled electrician |
| | Supply voltage missing | Establish the power supply or activate the electric fuse |
| | On/off switch defective | Replace on/off switch |
| | Motor defective | Replace motor (repair at the manufacturer's premises) |
| | Pump defective | Replace pump (repair at the manufacturer's premises) |
| › Electric motor switches off during operation | Viscosity too high (medium) | Warm up the oil |
| | Electric motor overheated | Let the motor cool down, clean any contaminated ventilation slits |
| › Volume flow is clearly too low | Pump blocked | Replace pump (repair at the manufacturer's premises) |
| | Filter element contaminated | Let the motor cool down, clean any contaminated ventilation slits |
| › Volume flow is clearly too low | Pump blocked | Replace pump (repair at the manufacturer's premises) |
| | Filter element contaminated | Replace filter element |
| | Suction strainer contaminated | Replace / clean suction strainer |
| | Viscosity too high | Warm up the medium |
| | Suction height too large | Adjust suction height |
| | Leak on the suction side | Replace suction hose or seal connection points (re-tighten them) |
| › Operating noise too loud | Wear of the pump | Replace pump (repair at the manufacturer's premises) |
| | Filter element contaminated | Replace filter element |
| | Suction strainer contaminated | Replace / clean suction strainer |
| | Viscosity too high | Warm up the medium |
| | Suction height too large | Adjust suction height |
| | Leak on the suction side | Replace suction hose or seal connection points (re-tighten them) |
| | Wear of the pump | Replace pump |
| Filter unit standing on a vibration-sensitive surface (e.g. sheet metal) | Improve site conditions | |
| › Pump does not suck | Leak on the suction side | Replace suction hose or seal connection points (re-tighten them) |
| | Unit pumped empty (with refilling) | Prime the unit (0.3 l) |
| | Suction strainer clogged | Clean / replace suction strainer |
| › Oil on the fan wheel cover | Shaft seal leaky | Replace motor (repair at the manufacturer's premises) |
| | Residual oil at the housing after filter element change | Clean filter unit |
| › Oil leaking out of terminal box | Screwing leaky | Check the screw joints, re-tighten and / or seal them |

Table 7: Fault table

16.1 Device dimensions

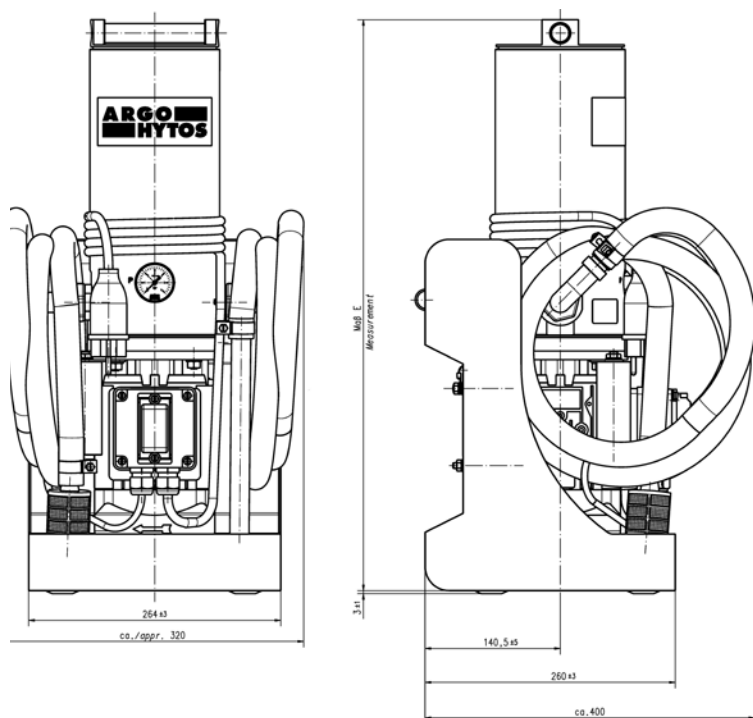

Fig. 11: Device dimensions

| Order No. | Suction connection | Pressure connection | Dimensions |
|--------------|--------------------|---------------------|------------|
| | A | B | E |
| FA 016-11000 | ∅ 44 | ∅ 20 | 601 |
| FA 016-11010 | ∅ 44 | ∅ 20 | 589 |
| FA 016-11100 | ∅ 44 | ∅ 20 | 601 |
| FA 016-11110 | ∅ 44 | ∅ 20 | 589 |
| FA 016-11300 | ∅ 44 | ∅ 20 | 601 |
| FA 016-11370 | ∅ 44 | ∅ 20 | 601 |
| FA 016-11600 | ∅ 44 | ∅ 20 | 601 |

16.2 Technical data

| | | |
|------------------------------|---|--|
| Nominal flow rate | l/m (50 Hz) | 16 |
| | l/m (60 Hz) | 19 |
| Pressure limiting valve | bar | 3,5 ± 0,5 |
| Max. operating pressure | bar | 4 |
| Filter element | | FA 016-11000 Y7.1220-05 $\beta_8(c) \geq 200$ |
| | | FA 016-10100 Y7.1220-05 $\beta_8(c) \geq 200$ |
| | | FA 016-11100 V7.1220-113 $\beta_3(c) \geq 200$ |
| | | FA 016-11110 V7.1220-113 $\beta_3(c) \geq 200$ |
| | | FA 016-11300 V7.1220-13 $\beta_5(c) \geq 200$ |
| | | FA 016-11370 V7.1220-13 $\beta_5(c) \geq 200$ |
| | | FA 016-11600 V7.1220-06 $\beta_{12}(c) \geq 200$ |
| Clogging indicator | | Pressure gauge DG 200-16 green: 0 - 2,7 bar red: ab 2,7 bar |
| Suction strainer - mesh size | µm | 600 |
| Suction side | | Hose DN 20 with suction strainer, length 1.8 m |
| Pressure side | | Hose DN 20 with discharge pipe, length 2.0 m |
| Electric drive | 1 ~230 V Motor; 50 Hz; 0,45 kW, n=3.000 min ⁻¹ | FA 016-11000, -11010, -11100, -11300, -11300F, -11600 |
| | 1~110 V Motor; 50/60 Hz; 0,45 kW, n=3000 min ⁻¹ | FA 016-11110, -11370 |
| Tare weight | kg | ca. 18,8 |
| Sound power level | db(A) max. | 80 (under operating conditions permitted for continuous operation) |
| | | 93 (under operating conditions permitted for short-term operation) |
| Dimensions (L x B x H) | mm | 320 x 589 / 601 x 260 (400) |

16.3 Operating conditions

| | | |
|-------------------------------|------------------------|---------------------------------|
| Permissible temperature range | Hydraulic fluid °C | 0 ... 65 (note viscosity range) |
| | Ambient temperature °C | 0...50 |

! CAUTION

| | |
|---|--|
|  | <p>Risk of burns</p> <p>Contact temperatures according to DIN EN563 (3) and DIN EN13202 (4) may be exceeded during operation.</p> <p>▶ Allow the filter unit to cool down before touching it.</p> |
|---|--|

| | | |
|-----------------------------|---|----------|
| Permissible viscosity range | mm ² /s (continuous operation) | 15 - 200 |
| | mm ² /s (max. short-term operation) (up to a total duration of 20 hours during the period of use of the unit) | 15 - 400 |

NOTE

| |
|---|
| <p>Varying viscosity behavior</p> <p>▶ Viscosities of a medium are always temperature-dependent.</p> |
|---|

| | | |
|---|-------------------------------------|--------------|
| Admissible suction heights | m (max.) first use | 1.0 |
| | m (max.) operating status | 2.0 |
| Resistant to environmentally friendly and petroleum based fluids. Before use with synthetic fluids please contact the manufacturer. | | |
| Work position | Abitrarily, perferably standing | |
| Mains fuse | 230 V, 50/60 Hz, 110 V, 50/60 Hz | 10 - 16 Amps |

16.4 Hydraulic circuit diagrams

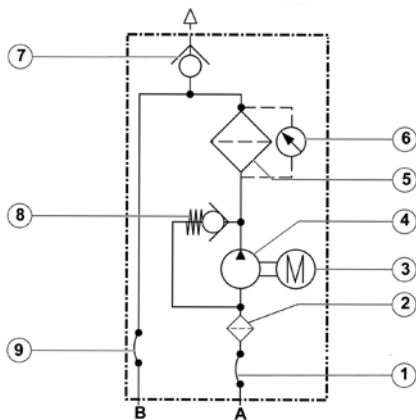

Fig. 12: Hydraulic circuit diagram

- | | |
|--------------------|---------------------------|
| 1 Suction hose | 6 Clogging Indicator |
| 2 Suction strainer | 7 Ventilating valve |
| 3 Motor | 8 Pressure limiting valve |
| 4 Pump | 9 Pressure hose |
| 5 Filter | |

17.1 EC-Declaration of Conformity

EU - Konformitätserklärung
EU - Declaration of Conformity



ARGO-HYTOS GMBH
Industriestraße 9
76703 Kraichtal-Menzingen

Tel.: +49 72 50 / 76 0
Fax: +49 72 50 / 76 199
www.argo-hytos.com

Die EU - Konformitätserklärung gilt für folgendes
Gerät:

The EU - Declaration of Conformity applies to
the following unit:

Filteraggregat

Filter Unit

FA 008

Wir bestätigen die Übereinstimmung mit den
wesentlichen Anforderungen der europäischen
Richtlinie(n):

We confirm the conformity according to the
essential requirements of the European
directive(s):

Maschinenrichtlinie 2006-42-EG

Machinery Directive 2006/42/EC

EMV Richtlinie 2004/108/EG

EMC Directive 2004/108/EC

Folgende Norm(en) wurde(n) angewandt:

The following standard(s) was (were) applied:

DIN EN 809
DIN EN 60204-1 (VDE 0113-1: 2007-06)

Kraichtal, 11.05.2016

(Ort und Datum der
Ausstellung)

(Place and date of issue)

(Unterschrift) Roman Krähling/
Dokumentenverantwortlicher

(Signature) Roman Krähling /
Responsible for documents

(Unterschrift) Dr. Marcus Fischer/
Technischer Geschäftsführer

(Signature) Dr. Marcus Fischer/
Technical director

17.2 Spare parts list

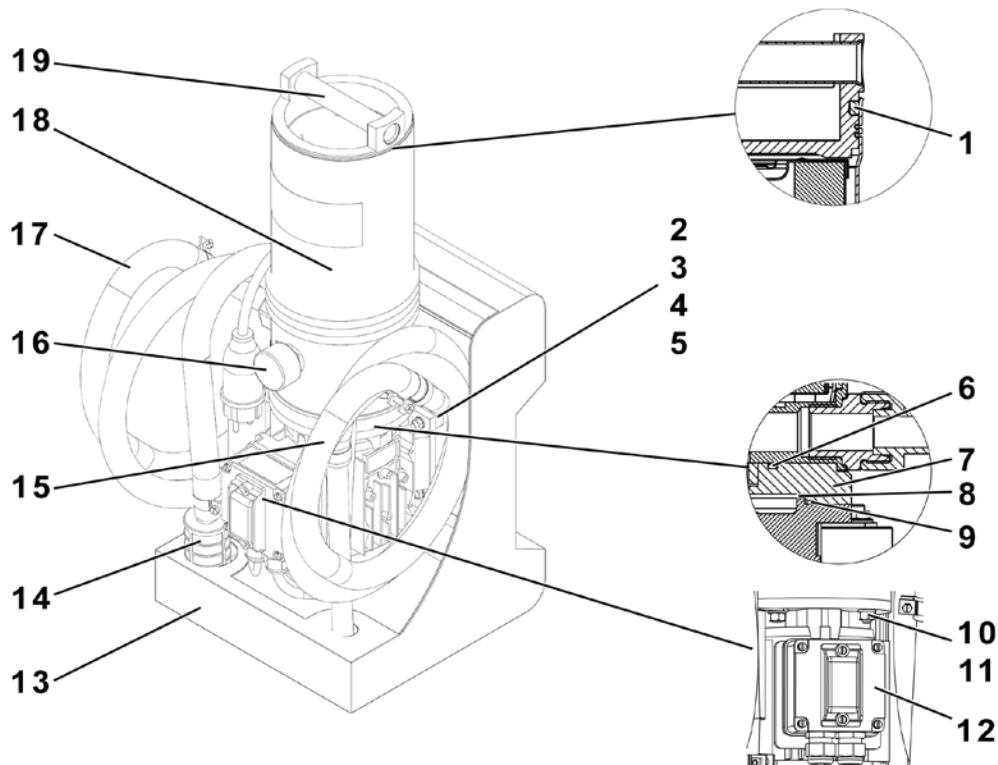

Fig. 13: Spare parts list

| Pos. | Designation | Pcs. | Order No. | Remark |
|------|---------------------|------|---|--|
| 1 | O-Ring D117,48x5,33 | 1 | N007.1175 | |
| 2 | Rubber buffer | 4 | FNA 008.0705 | |
| 3 | Washer 6,4 | 4 | 13534900 | ISO 7090 |
| 4 | Hexagon nut M6 | 4 | 11748300 | ISO 4032 |
| 5 | Distance piece | 4 | FA 016.0724 | |
| 6 | O-Ring D63,09x3,53 | 1 | N007.0634/2 | |
| 7 | Pump plate complete | 1 | FNA 008.1230 | bestehend aus Pumpenplatte, Aussenrotor und Innenrotor |
| 8 | Flat gasket | 1 | N031.1401 | |
| 9 | O-Ring D94,92x2,62 | 1 | N007.0952 S | |
| 10 | Washer 8,4 | 4 | 118746005 | ISO 7090 |
| 11 | Hexagon nut M8 | 4 | 11874700 | ISO 4032 |
| 12 | Motor | 1 | FA 016.1700 FA 016.1715 | bei FA 016-11000, -11110, -11300, -11600 bei FA 016-11010, -11110, -11370 |
| 13 | Tray | 1 | FA 016.0101 | |
| 14 | Suction strainer | 1 | FA 016.0301 | |
| 15 | Pressure hose | 1 | FNA 016.0107 | |
| 16 | Pressure gauge | 1 | DG 200-16 | |
| 17 | Suction hose | 1 | FA 016.0106 | |
| 18 | Filter element | 1 | Y7.1220-05 V7.1220-06 V7.1220-13 V7.1220-113 | bei FA 016-11000, -11010 bei FA 016-11600 bei FA 016-11300, -11370 bei FA 016-11100, -11110 |
| 19 | Cover complete | 1 | FNA 008.1260 | |

Table 9: Spare parts list

International

ARGO-HYTOS worldwide

| | | |
|-----------------------|--|--|
| Benelux | ARGO-HYTOS B. V. | info.benelux@argo-hytos.com |
| Brazil | ARGO-HYTOS AT Fluid Systems Ltda. | info.br@argo-hytos.com |
| China | ARGO-HYTOS Fluid Power Systems (Yangzhou) Co., Ltd. ARGO-HYTOS Fluid Power Systems (Beijing) Co., Ltd. ARGO-HYTOS Hong Kong Ltd. | info.cn@argo-hytos.com info.cn@argo-hytos.com info.hk@argo-hytos.com |
| Czech Republic | ARGO-HYTOS GMBH ARGO-HYTOS Protech s.r.o | info.cz@argo-hytos.com info.protech@argo-hytos.com |
| France | ARGO-HYTOS SARL | info.fr@argo-hytos.com |
| Germany | ARGO-HYTOS GMBH | info.de@argo-hytos.com |
| Great Britain | ARGO-HYTOS PVT. Ltd. | info.uk@argo-hytos.com |
| India | ARGO-HYTOS PVT. LTD. | info.in@argo-hytos.com |
| Italy | ARGO-HYTOS srl | info.it@argo-hytos.com |
| Poland | ARGO-HYTOS Polska sp. z o.o. | info.pl@argo-hytos.com |
| Russia | ARGO-HYTOS LLC | info.ru@argo-hytos.com |
| Scandinavia | ARGO-HYTOS Nordic AB | info.se@argo-hytos.com |
| Turkey | ARGO-HYTOS | info.tr@argo-hytos.com |
| USA | ARGO-HYTOS Inc. | info.us@argo-hytos.com |

