

Male J.I.C. (37°) X Female Pipe (N.P.T.F.)

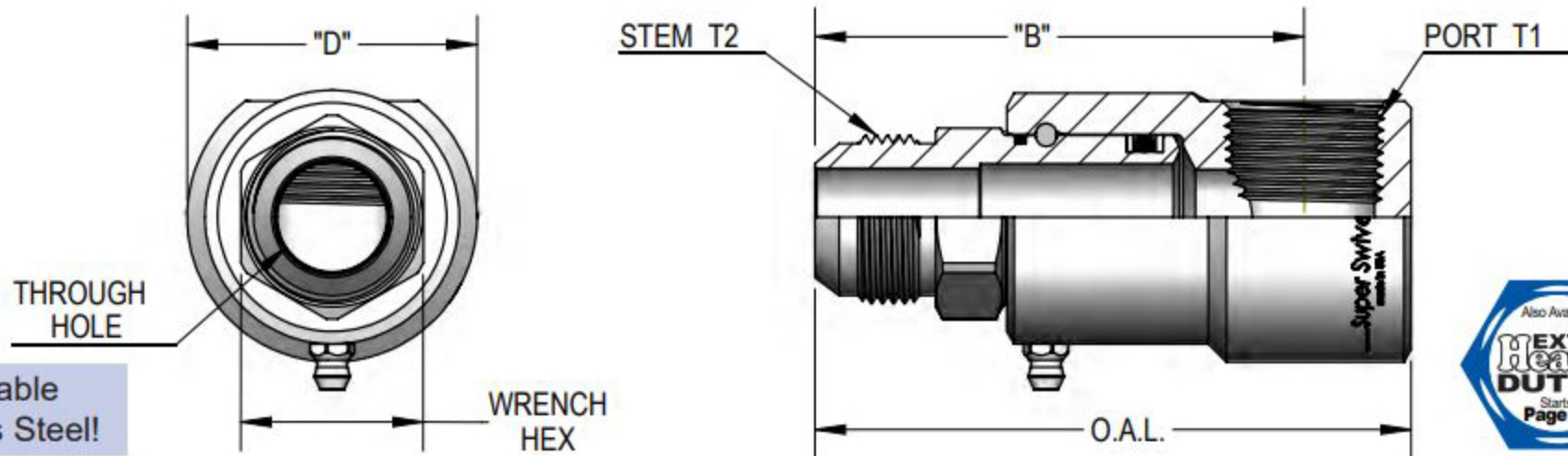

Not Available
In Stainless Steel!



PART NUMBER	O.A.L.	DIM. B	DIM. D Ø	WRENCH/HEX	PORT T1	STEM T2	SWG. RADIUS	MAX. P.S.I.G.	THROUGH HOLE
9 SS 4 MJ 4 X FP 25	2.570	2.200	1.190	0.625	1/4-18 N.P.T.F.	7/16-20 U.N.	0.525	5000	0.172
9 SS 4 MJ 6 X FP 25	2.590	2.220	1.190	0.625	1/4-18 N.P.T.F.	9/16-18 U.N.	0.525	5000	0.250
9 SS 8 MJ 6 X FP 38	2.970	2.430	1.495	1.000	3/8-18 N.P.T.F.	9/16-18 U.N.	0.651	5000	0.297
9 SS 8 MJ 8 X FP 38	3.080	2.460	1.495	1.000	3/8-18 N.P.T.F.	3/4-16 U.N.	0.651	5000	0.391
9 SS 8 MJ 10 X FP 38	3.173	2.560	1.495	1.000	3/8-18 N.P.T.F.	7/8-14 U.N.	0.651	5000	0.484
9 SS 8 MJ 8 X FP 50	3.070	2.523	1.495	1.000	1/2-14 N.P.T.F.	3/4-16 U.N.	0.581	5000	0.391
9 SS 8 MJ 10 X FP 50	3.170	2.623	1.495	1.000	1/2-14 N.P.T.F.	7/8-14 U.N.	0.581	5000	0.484
9 SS 12 MJ 12 X FP 75	3.555	2.890	1.710	1.125	3/4-14 N.P.T.F.	11/16-12 U.N.	0.643	4500	0.609
9 SS 16 MJ 16 X FP 100	4.495	3.687	2.160	1.375	1-11 1/2 N.P.T.F.	11/16-12 U.N.	0.741	4000	0.827
9 SS 20 MJ 20 X FP 125	4.913	3.945	2.700	1.750	1 1/4-11 1/2 N.P.T.F.	15/8-12 U.N.	1.049	4000	1.078
9 SS 24 MJ 24 X FP 150	6.275	5.045	2.915	2.000	1 1/2-11 1/2 N.P.T.F.	17/8-12 U.N.	1.072	4000	1.312
9 SS 32 MJ 32 X FP 200	7.360	5.990	3.667	2.625	2-11 1/2 N.P.T.F.	2 1/2-12 U.N.	1.386	3000	1.780