

Return Filters - Lightline
RFL 090 · RFL 100

 In-line mounting · Connection G $\frac{3}{4}$ / -12 SAE · Nominal flow rate up to 120 l/min / 32 gpm

M

In-line Return Filter RFL 090

Description
Application

In the return line circuits of hydraulic systems.

Filter maintenance

By using a clogging indicator the correct moment for maintenance is stated and thus the optimum utilization of the filter life is guaranteed.

Materials

Filter head:	Aluminum alloy
Filter bowl:	Polyamide, GF reinforced
Seals:	NBR (FPM on request)
Filter media:	EXAPOR®Light - inorganic multi-layer microfiber web Paper - cellulose web, impregnated with resin

Accessories

Electrical and optical clogging indicators are available on request. For technical data and dimensions see datasheet 60.20.

Characteristics
Nominal flow rate

Up to 120 l/min / 32 gpm.

The nominal flow rates indicated by ARGO-HYTOS lightline are based on the following features:

- › Closed by-pass valve at $v \leq 150 \text{ mm}^2/\text{s}$ / 698 SUS
- › Element service life > 500 operating hours at an average fluid contamination of 0.07 g per l/min / 0.27 g per gpm flow volume
- › Flow velocity in the connection lines $\leq 6 \text{ m/s}$ / 20 ft/s

Connection

Threaded ports according to ISO 228 or DIN 13 and SAE standard J514. Sizes see Selection Chart, page 3, (other port threads on request).

Filter fineness

 10 $\mu\text{m(c)}$... 30 $\mu\text{m(c)}$
 β -values according ISO 16889 (see diagrams)

Hydraulic fluids

Mineral oil and biodegradable fluids (HEES and HETG, see info-sheet 00.20).

Temperature range

-30 °C ... +100 °C (temporary -40 °C ... +120 °C)

-22 °F ... +212 °F (temporary -40 °F ... +248 °F)

Operating pressure

Max. 10 bar / 145 psi

Mounting position

Vertical mounting to be preferred, filter head on top.

Dimensions

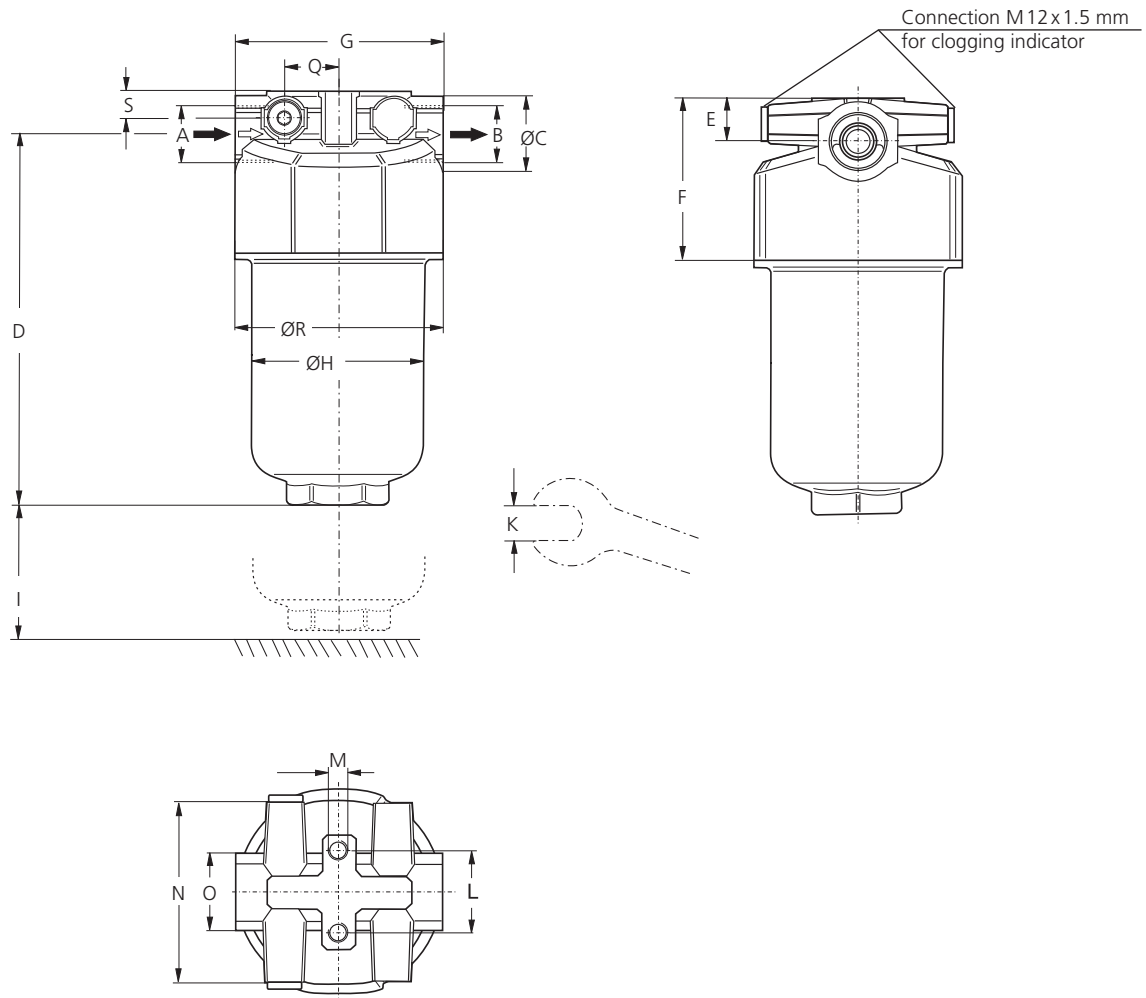

Measurements

Type [mm]	A	B	C	D	E	F	G	H	I	K	L	M Ø / depth	N	O	Q	R	S
RFL 090	G ³ / ₄	G ³ / ₄	35	178	20	74	95	80	70	AF 41	38.1	M8 / 15	82	AF 36	25	95	12
RFL 100	G ³ / ₄	G ³ / ₄	35	212	20	74	95	80	70	AF 41	38.1	M8 / 15	82	AF 36	25	95	12

Type [inch]	A	B	C	D	E	F	G	H	I	K mm	L	M Ø / depth	N	O mm	Q
RFL 090	-12 SAE*	-12 SAE*	1.38	7.01	0.79	2.91	3.74	3.15	1.57	AF 41	1.50	M8 / 0.6	3.23	AF 36	0.98
RFL 100	-12 SAE*	-12 SAE*	1.38	8.35	0.79	2.91	3.74	3.15	1.57	AF 41	1.50	M8 / 0.6	3.23	AF 36	0.98

Type [inch]	R	S													
RFL 090	3.74	0.47													
RFL 100	3.74	0.47													

*Corresponds to 1¹/₁₆ -12 UN - 2B

Symbol

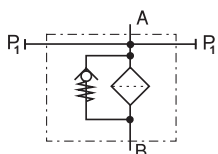

Ordering Code

Filter assembly

Order example:

RFL - 090 - UC - I2 - OM - 100

Type of filter	Code
Return Filter, In-line	RFL

Flow rate, max.	Code
100 l/min / 26 gpm	090
120 l/min / 32 gpm	100

Connection thread	Code
G $\frac{3}{4}$	GC
-12 SAE	UC

Filter fineness	Code
10 μ m (10EL)	G2
16 μ m (16EL)	I2
30 μ m (30P)	N3

Air breather	Code
without air breather	100

Bypass setting	Code
2.5 bar / 36 psi (for 10EL, 16EL)	OM
1.5 bar / 22 psi (for 30P)	KM

Filters delivered with 2 plugged connections
M12 x 1.5 for clogging indicators.

Spare filter element

Order example:

F3.0714-08

Filter media	Code
EXAPOR®Light	F
Paper	P

Length	Code
for RFL 090	14
for RFL 100	17

Filter fineness	Code
10EL	6
16EL	8
30P	1

Spare parts

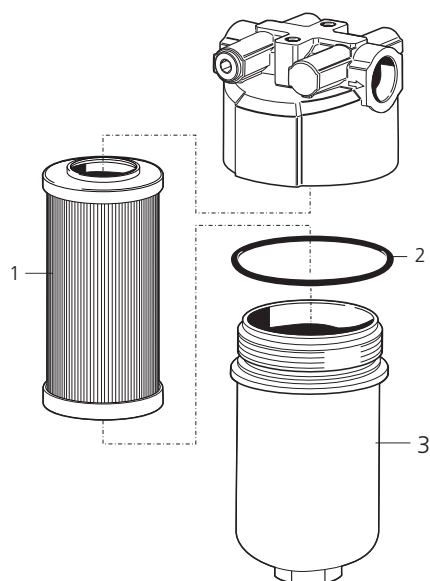

Pos.	Designation	Part No.
1	Replacement filter element	see above
2	O-ring 82.14 x 3.53 mm 3.23 x 0.14 inch	N007.0824
3	Filter bowl RFL 090	E 068.0101
3	Filter bowl RFL 100	E 068.0102

The functions of the complete filters as well as the outstanding features of the filter elements assured by ARGO-HYTOS can only be guaranteed if original ARGO-HYTOS spare parts are used.

Δp-curves for complete filters

D1 Pressure drop as a function of the **flow volume**
at $v = 35 \text{ mm}^2/\text{s} / v = 162 \text{ SUS}$ (0 = housing empty)

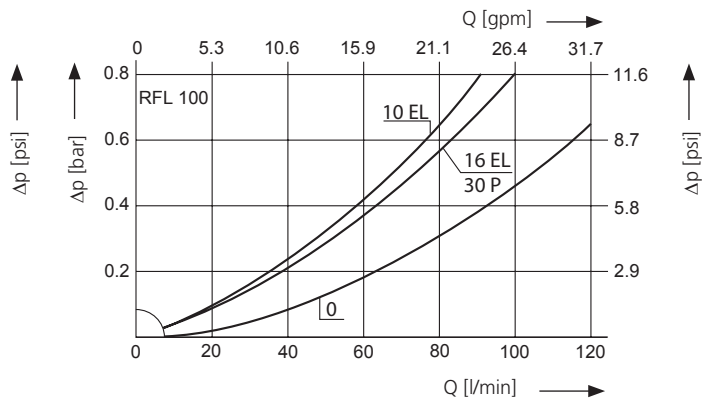
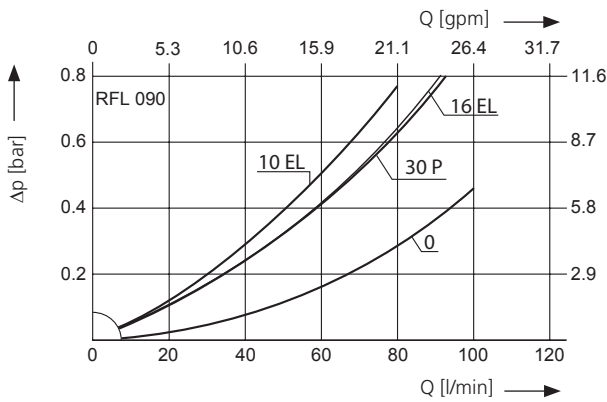

Filter fineness curves

Dx Filtration ratio β as a function of particle size x obtained by the Multi-Pass-Test according to ISO 16889

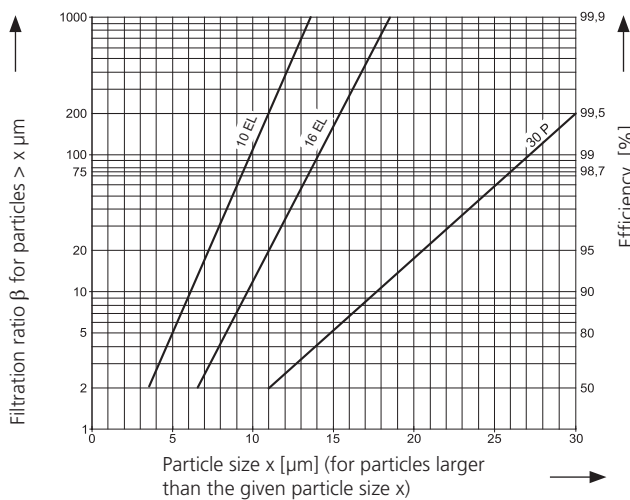

The abbreviations represent the following β -values resp. finenesses:

For EXAPOR®Light and Paper elements:

- 10 EL = $\beta_{10(c)} = 200$ EXAPOR®Light
- 16 EL = $\beta_{16(c)} = 200$ EXAPOR®Light
- 30 P = $\beta_{30(c)} = 200$ Paper

Based on the structure of the filter media of the 30P paper elements, deviations from the printed curves are quite probable.

For special applications, finenesses differing from these curves are also available by using special composed filter material.

Quality Assurance

Quality management according to DIN EN ISO 9001

To ensure constant quality in production and operation, ARGO-HYTOS filter elements undergo strict controls and tests according to the following ISO standards:

- ISO 2941 Verification of collapse / burst pressure rating
- ISO 2942 Verification of fabrication integrity (Bubble Point Test)
- ISO 2943 Verification of material compatibility with fluids
- ISO 3968 Evaluation of pressure drop versus flow characteristics
- ISO 16889 Multi-Pass-Test (evaluation of filter fineness and dirt-holding capacity)
- ISO 23181 Determination of resistance to flow fatigue using high viscosity fluid

Various quality controls during the production process guarantee the leakfree function and solidity of our filters.

Illustrations may sometimes differ from the original. ARGO-HYTOS is not responsible for any unintentional mistake in this specification sheet.